

Masina CAD-CAM 5 axe mediu uscat T20D ZOTION

Pret:

**101.743,72 lei TVA
inclusa**



Descriere produs:

Noul model ZOTION T20D CAD-CAM 5 axe de frezare dentara, este o masina de frezare uscata cu 5 axe, pentru frezarea discurilor de zirconiu, a blocurilor de ceara, a materialelor PMMA si PEEK.

Masina de frezat CAD CAM cu 5 axe constituie o tehnologie dentara digitala moderna. Prin aceasta tehnologie se utilizeaza sisteme avansate CAD/CAM pentru a finaliza restaurarile dentare si alte materiale dentare precise in doar cateva minute.

In comparatie cu masinile de frezat CAD-CAM traditionale, realizate manual, aceasta masina cu 5 axe ofera o precizie si o acuratete mai mare.

Masina de frezat utilizeaza dispozitive CNC avansate pentru a sculpta dinti si restaurari de toate formele si dimensiunile cu o mare precizie. Datorita acuratetei si vitezei sale, ii ajuta pe stomatologi sa finalizeze tratamentele dentare intr-o perioada scurta de timp, imbunatatind satisfactia pacientilor.

In plus, aceasta poate imbunatati eficienta muncii, reduce timpul de asteptare al pacientilor, faciliteaza efectuarea de catre stomatologi a testelor ocluzale si reduce consultatiile secundare inutile.

D TEHNICALDENT

Intrarea Sulfinei 94 Magurele, Ilfov. Tel: 021 312 56 60, E-mail: office@tehnicaldent.ro IBAN: RO17 RNCB

0068 0043 7192 0001 Nr. Inreg. Reg. Com.: J/09/137/99, Cod fiscal: RO 117 58 273

De asemenea, este posibil sa se produca restaurari dentare mai precise si mai confortabile, cum ar fi coroane temporare sau permanente, punti etc., pentru a oferi pacientilor o experienta de tratament mai bogata din punct de vedere tehnologic.



Front



Back



Left



Right

Avantaje

1. Se poate calibra automat

D TEHNICALDENT

Intrarea Sulfinei 94 Magurele, Ilfov. Tel: 021 312 56 60, E-mail: office@technicaldent.ro IBAN: RO17 RNCB

0068 0043 7192 0001 Nr. Inreg. Reg. Com.: J/09/137/99, Cod fiscal: RO 117 58 273

2. Poate continua frezarea de la linia de oprire în cazul în care a avut loc o pana de curent. Nu este nevoie sa frezeze de la primul pas. Economiseste mult timp pentru pacienti

3. Greutate redusa si dimensiuni mici, usor de mutat

4. Cea mai buna alegere pentru clinica stomatologica / laborator dentar

5. Forta axului este foarte puternica, cu o viteza de pana la 60.000 rpm

6. Precizie ridicata

7. Taiere in unghi inalt.

05.

Size



Tool magazine

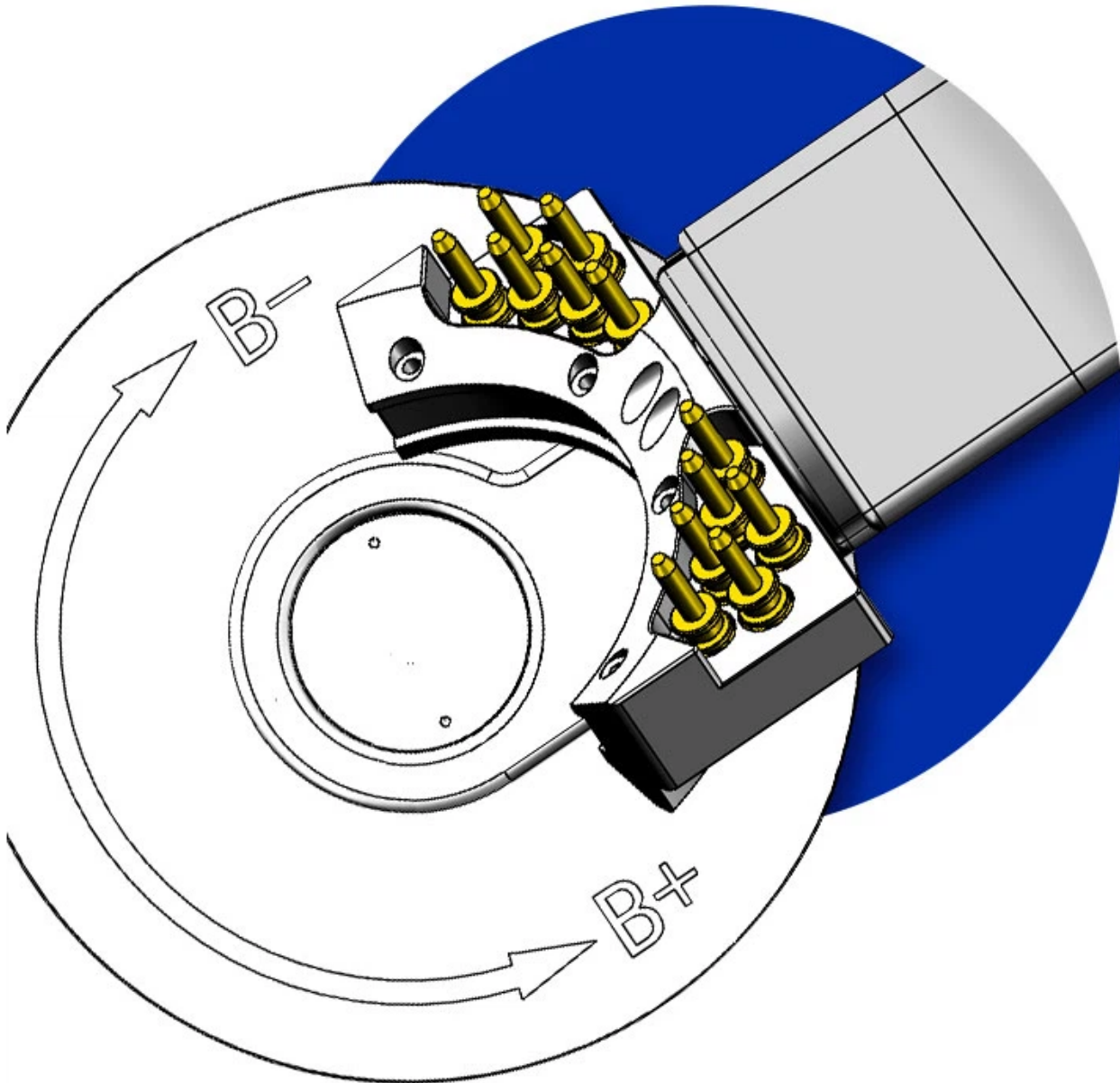

Masina de frezat CAD-CAM 5 axe T20D este prevazuta cu 2 tipuri de freze, tipul 1 pentru frezarea blocurilor de zirconiu (de asemenea, pentru frezarea blocurilor de ceara), tipul 2 pentru frezarea PMMA (de asemenea, pentru frezarea materialului PEEK)

Large rotation range

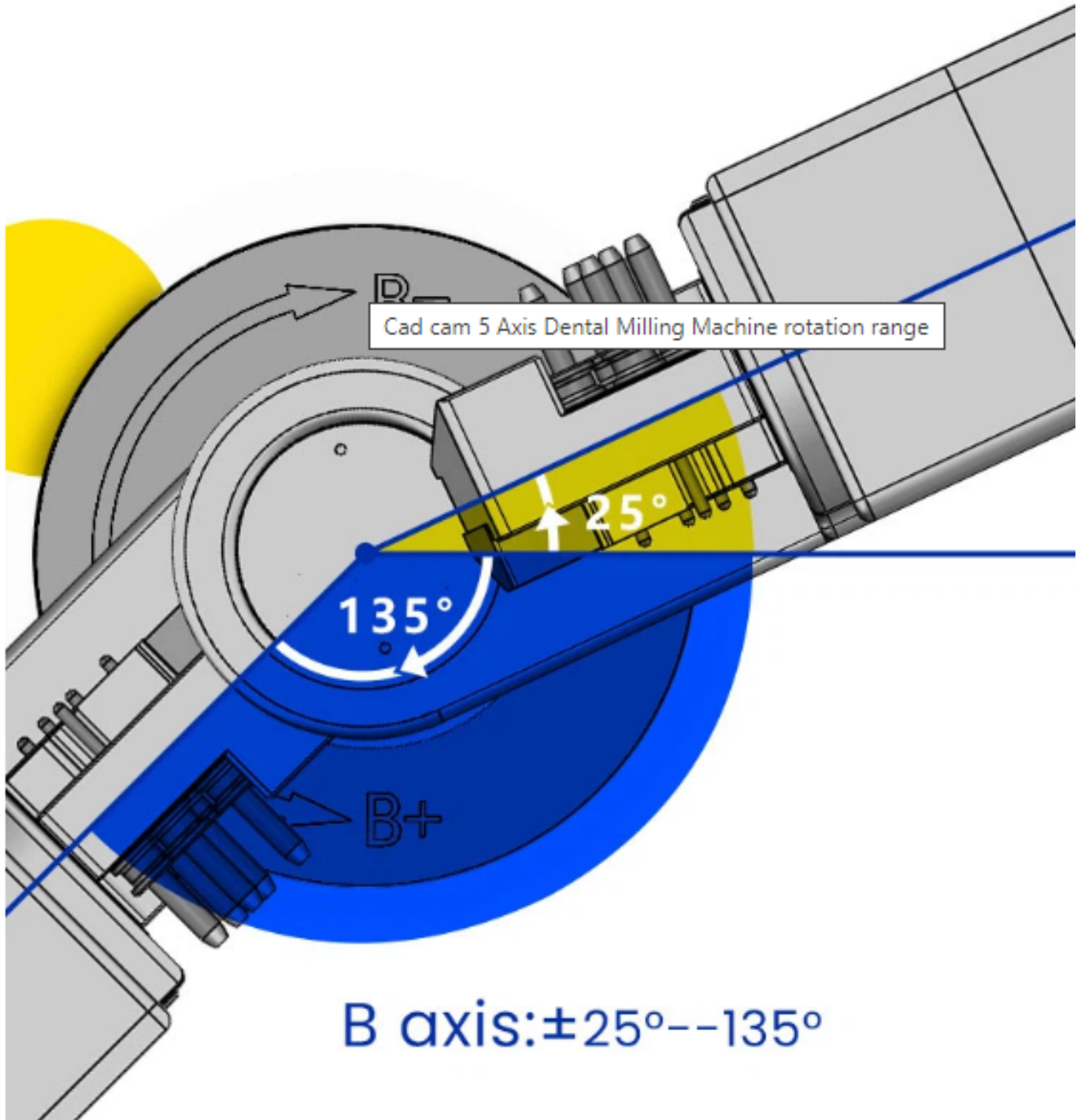

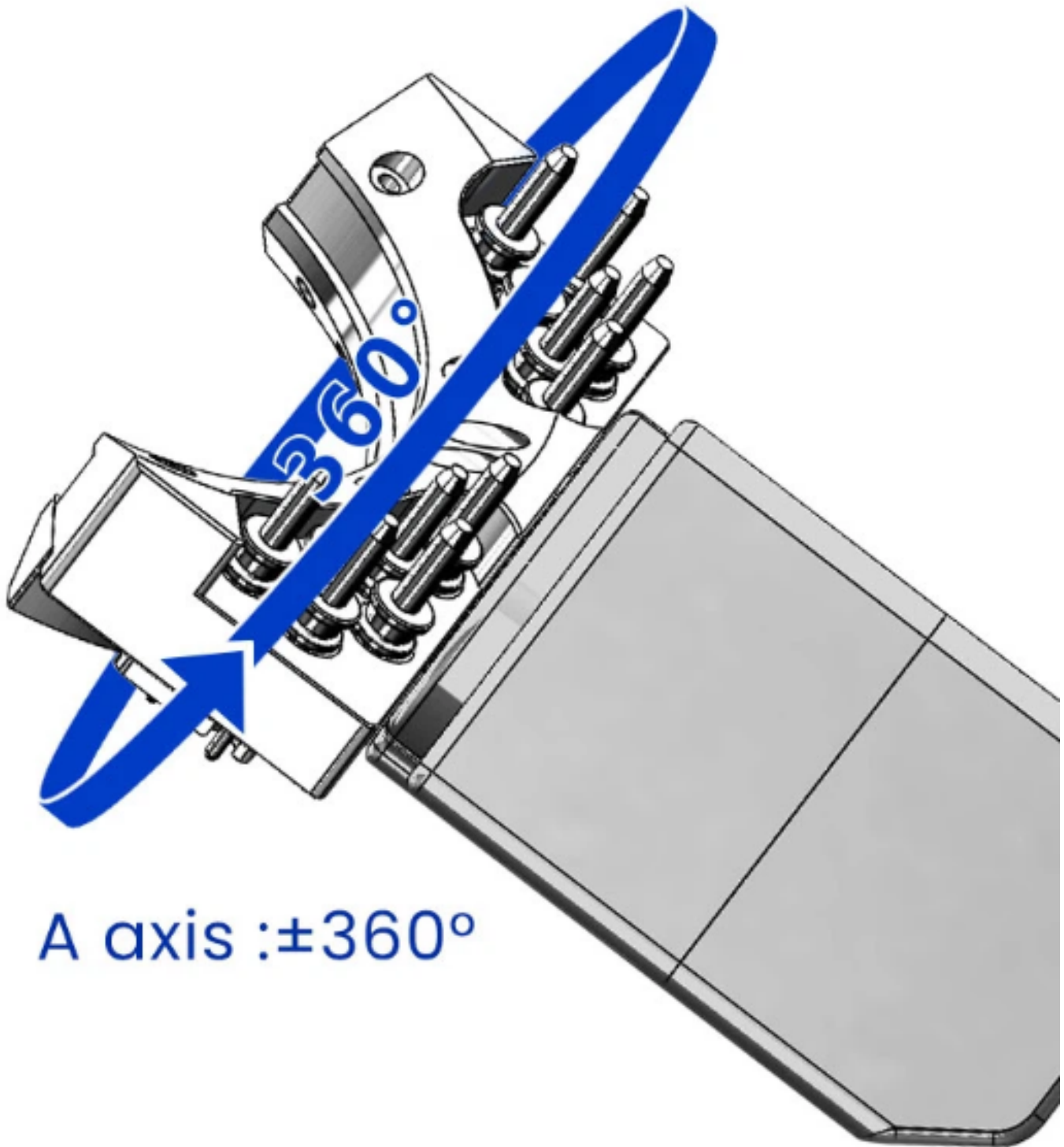

A axis : ±360°

Auto calibration supported



The calibration
point of spindle



The track of
spindle

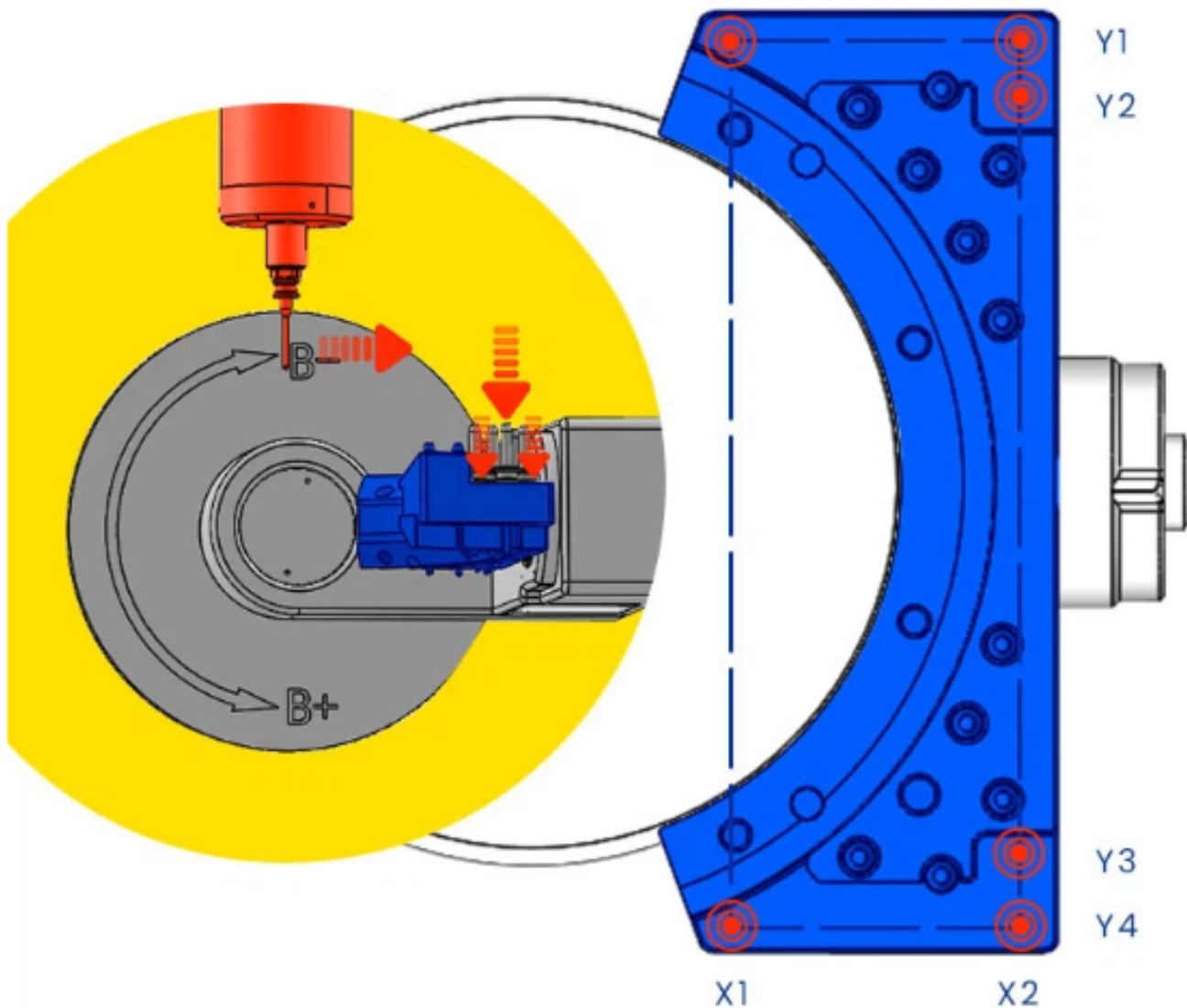

D TEHNICALDENT

Intrarea Sulfinei 94 Magurele, Ilfov. Tel: 021 312 56 60, E-mail: office@tehnicaldent.ro IBAN: RO17 RNCB
0068 0043 7192 0001 Nr. Inreg. Reg. Com.: I/09/137/09 Cod fiscal: RO 117 58 273

What does T20D mill?



PMMA



WAX BLOCK



PEEK



ZIRCONIA BLOCK

TEHNICALDENT

Intrarea Sulfinei 94 Magurele, Ilfov. Tel: 021 312 56 60, E-mail: office@tehnicaldent.ro IBAN: RO17 RNCB 0068 0043 7192 0001 Nr. Inreg. Reg. Com. : I/09/137/09 Cod fiscal: RO 117 58 273



Features

color: white and grey
Net weight: 50KG

Accessories



Ce materiale poate freze	Zirconia.Wax.Pmma.peek
XYZ viteza maxima	Z axis 60000mm/min XY axis 6000
Viteza Spindle	6000-60000RPM
Rotary axis Stroke	Aaxis:+360° Baxis+25°--135°

TEHNICALDENT

Intrarea Sulfinei 94 Magurele, Ilfov. Tel: 021 312 56 60, E-mail: office@technicaldent.ro IBAN: RO17 RNCB
0068 0043 7192 0001 Nr. Inreg. Reg. Com. J/09/137/99, Cod fiscal. RO 117 58 273

Tip magazie unelte	Magazie de unelte automatica profesionale
Cantitate unelte	12 unelte
Dimensiune unelte	Diametru 4mm*45mm lungime totala
Control Code	NC Code
Interfata program	USB2.0, 100M network port
Alimentare	AC 220V+10% 50/60Hz
Putere Spindle	800W
Greutate neta	50KG
Dimensiune	W*L*H 420mm*540mm*580mm
Zgomot lucru	45 decibel in standby,70 decibel in in functie de materialul in care se fr

Prezentare video